

CTLQ1812CF Series

From 1.0 μ H to 470 μ H



SPECIFICATIONS

Part numbers indicate inductance tolerance available.
K = $\pm 10\%$, M = $\pm 20\%$

Part Number	Inductance (μ H)	L Test Freq. (_Hz)	DCR Max. (Ω)	SRF Min. (MHz)	Rated DC Max. (mA)
CTLQ1812CF-1R0M	1.0	1M	0.08	100	1080
CTLQ1812CF-1R5M	1.5	1M	0.09	85	1000
CTLQ1812CF-2R2M	2.2	1M	0.11	60	900
CTLQ1812CF-3R3M	3.3	1M	0.13	47	800
CTLQ1812CF-4R7M	4.7	1M	0.15	35	750
CTLQ1812CF-6R8M	6.8	1M	0.20	30	720
CTLQ1812CF-100K	10	1M	0.24	23	650
CTLQ1812CF-150K	15	1M	0.32	20	570
CTLQ1812CF-220K	22	1M	0.60	15	420
CTLQ1812CF-330K	33	1M	1.00	12	310
CTLQ1812CF-470K	47	1M	1.10	10	280
CTLQ1812CF-680K	68	1M	1.70	8.4	220
CTLQ1812CF-101K	100	1M	2.20	6.8	190
CTLQ1812CF-151K	150	1M	3.50	5.5	130
CTLQ1812CF-221K	220	1M	4.00	4.5	110
CTLQ1812CF-331K	330	1M	6.80	3.6	100
CTLQ1812CF-471K	470	1k	8.50	3.0	90

PHYSICAL DIMENSIONS

Size	A	B	C	D	E	F Min.	G Min.
mm	4.5 \pm 0.3	2.6 \pm 0.2	3.6 \pm 0.2	3.2 \pm 0.2	3.2 \pm 0.2	1.0	1.0
inches	0.18 \pm 0.01	0.10 \pm 0.008	0.14 \pm 0.008	0.12 \pm 0.008	0.12 \pm 0.008	0.04	0.04

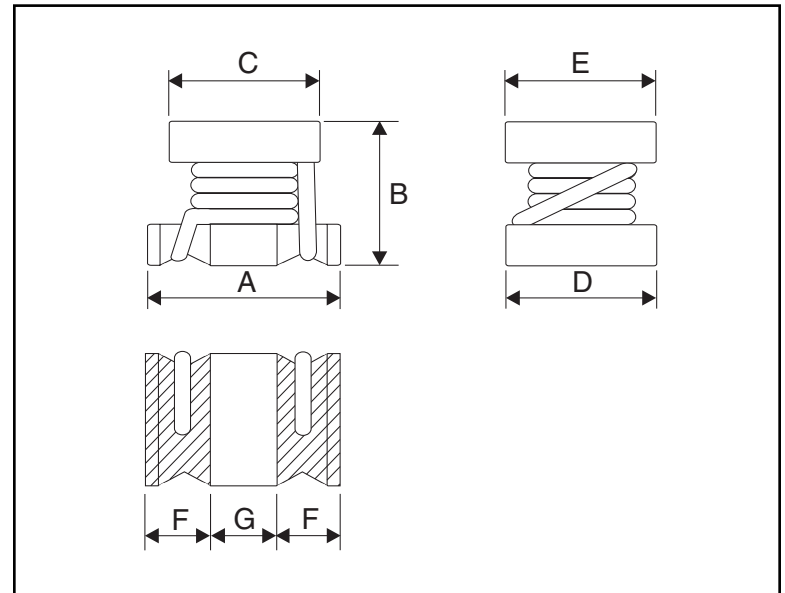

CHARACTERISTICS

- Description:** SMD wire-wound chip inductors
- Applications:** Power supplies for VTR, OA equipment, LCD televisions, PC notebooks, portable communication equipment, DC/DC converters.
- Operating Temperature:** -40°C to 125°C (including self-temperature rise)
- Inductance Tolerance:** $\pm 10\%$, $\pm 20\%$
- Packaging:** Tape & Reel.
- Testing:** Inductance is tested on an HP4285A at specified frequency.
- Pads:** Soft copper and pre-tinned.
- Miscellaneous:** **RoHS Compliant.**
- Additional Information:** Additional electrical & physical information available upon request.
- Samples available. See website for ordering information.**